

1603E

1/16 DIN Temperature Controller



Features

- **Built-in Programming Port for Saving and Downloading Set-Up Parameters**
- **Programming w/o Internal Hardware Switch**
- **SMART Self-Tuning with Fuzzy Logic**
- **Heat, Cool or Heat/Cool Control Capability**
- **Up to 3 Outputs**
- **Universal Inputs TC, RTD**
- NEW!** • **Built-In Timer**
- **Logic Input for Timing Function or SP1/SP2 Selection**
- **Soft Start Power Limiting on Power-Up**
- **3-Year Warranty**



Chromalox[®]
PRECISION HEAT AND CONTROL

Description

The fully field configurable Chromalox model 1603E 1/16 DIN controller combines advanced hardware design and sophisticated electronic control technology into a compact, reliable 1/16 DIN package.

Applications

- Rubber Production, Polymerization and Synthetic Fibers Plants
- Packaging and Packing Equipment
- Extrusion Lines, Coextrusion Lines, Plastic Films and Injection Presses
- Fermentation Equipment, Reactors for Chemical and Pharmaceutical Industries
- Food Industries
- Environmental Chambers and Refrigeration

Easy to Install and Operate

The 1603E plug-in design requires only panel cutout, instrument mounting, setpoint adjustment to set up. Additional parameters are programmed via the front pushbuttons or via the Configuration Port.

Configuration Port

Each 1603E has a Configuration Port for remote set up of the controller. This feature allows the 1603E to be programmed from a PC without any connections for power.

Special Control Features

- **Heat/Cool Control Features**
Selection of Cooling Medium and Overlap
- **Soft Start-Timed Output Power Limit on Start-Up.** Allows a "warm up period" to protect the process and avoid thermal shock on start up
- **Control Output "Turn Off" Via Pushbuttons** if used during setup or controller becomes a monitor
- **Programmable offset of Process Temperature**

Timing Functions:

Using the digital input on the 1603E, one of several timing functions can be selected: These functions can either select between 2 set points or turn the output off after a selected time period. Applications: energy saving, cooking, cooking with end of cycle indication, paint mode and power off mode.

1603E Temperature Controller

Quality Construction and Reliability

Manufactured with SMT and verified with long burn-in times and temperature cycling, the 1603E is guaranteed for reliability and long, maintenance-free service.

NEMA 4X, IP65 Splashproof

Front Faceplate

Upper Display

(4 Green 7-Segment LEDs)

For process temperature, setpoint, timer. During configuration, shows the programmed value of selected parameter and the code.

Indicators Red LEDs

SMT SMART tuning is active

Indicators

Red LEDs

OUT 1

Load 1 output is on

OUT 2

Load 2 output is on

Programming Security Levels

Access to programmed parameters is protected by 4 security levels:

- Level 1 Set point and SMART self-tuning
- Level 2 All control parameters and alarm setpoint
- Level 3 Main configuration level
- Level 4 Special functions configuration

Large Target Pushbuttons Simplify Operator Adjustments



Enables SMART self-tuning. During configuration, scrolls back parameters without storing them.



Decrease/Increase Parameter Values



Scrolls parameter display forward and stores previous parameter value

SMART Self-Tuning

The model 1603E meets the application needs of operators with or without skills in temperature processes and PID control. SMART self-tuning automatically adjusts the controller to rapidly respond to all process changes. Sophisticated control features include:

- Start-up and continuous in-process tuning
- Continuous self-tuning without artificial upset
- Proven maximum suppression of overshoot

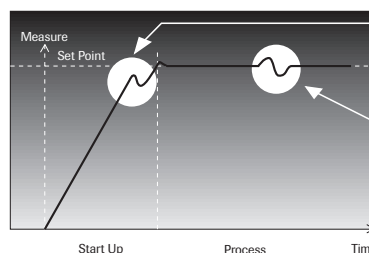

During Start-Up the SMART self-tuning function calculates the control parameters to optimize the rise to setpoint.

During Process SMART updates the control parameters as needed to respond to setpoint changes or a log change.

1603E Temperature Controller

TIMER FUNCTIONS

Four timer functions are provided in the new version of the 1601E/1603E. The timer selects between working and standby SP1 and SP2 setpoints or selects between SP and control power off.

Timer - Mode 1

"Energy saving" Mode

Functional overview:

When the machine is not used for a predefined time, the instrument automatically switches to a standby temperature setting.

Typical applications: Glue and laminating machines

Advantages:

- 1) Energy saving
- 2) Waste reduction
- 3) Extended maintenance interval

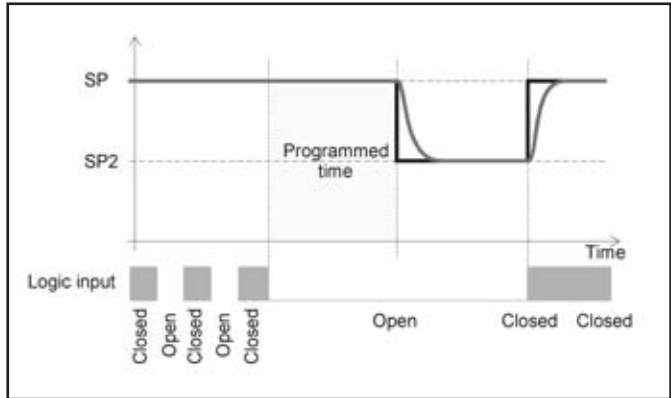

Timer - Mode 2

"Cooking" mode

Typical applications: Ovens, Bakeries, Thermostatic baths, Incubators

NOTE: When timer is running the lower display indicates time remaining. The input is a momentary contact closure from a pushbutton, PLC or other device.

Variants:

- "Guaranteed soak" timer operates when process is within defined temperature limits
- "Output power off" function instead of maintenance temperature

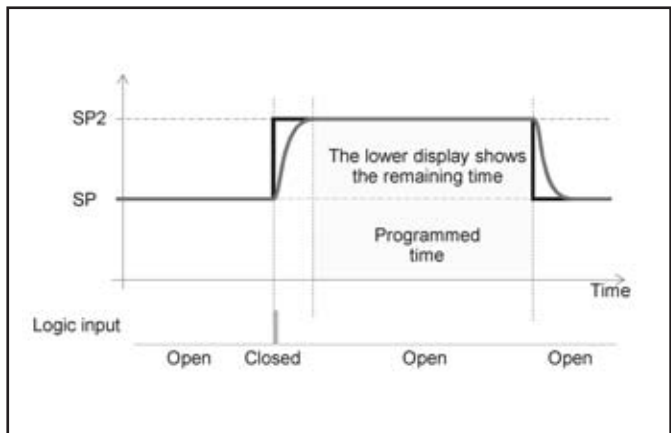

1603E Temperature Controller

Timer - Mode 3

Similar to "Cooking" mode but with indication for "End of cycle". Output two turns on after the process times out.

Typical applications:

Laboratory apparatus:

- Stirrer with hot plate
- Thermostatic baths
- Ultrasonic cleaning baths- Incubators

NOTE: a special version with internal audible alarm is available

Variants:

- "Guaranteed soak", timer operates when process is within defined temperature limits
- Maintenance temperature instead of "output power off" function

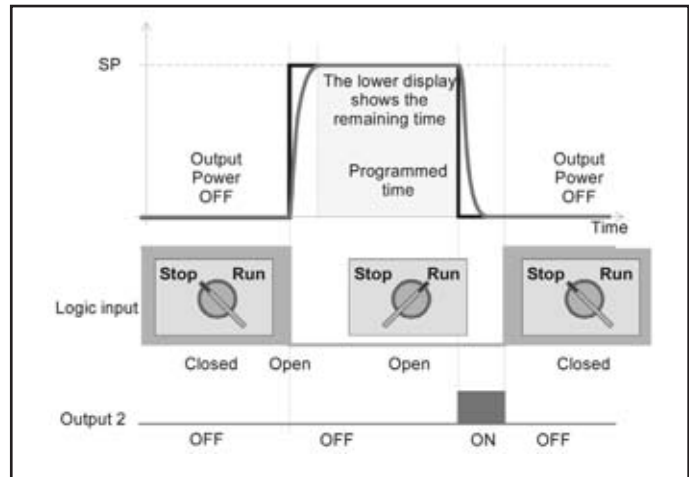

Timer - Mode 4

"Paint" mode.

Typical applications: - Paint drying ovens

Functional overview:

The timer starts when the set point 2 is selected. If the guaranteed soak function is selected, the timer starts when SP 2 is reached.

OP2 may be used to control air recirculation during the drying period as well as indicating the dryer is operating. OP2 is energized during the timing function.

NOTE: During the dry phase the lower display shows the remaining time.

Variants:

- "Guaranteed soak", timer operates when process is within defined temperature limits
- "Output power off" function instead of "painting" temperature.

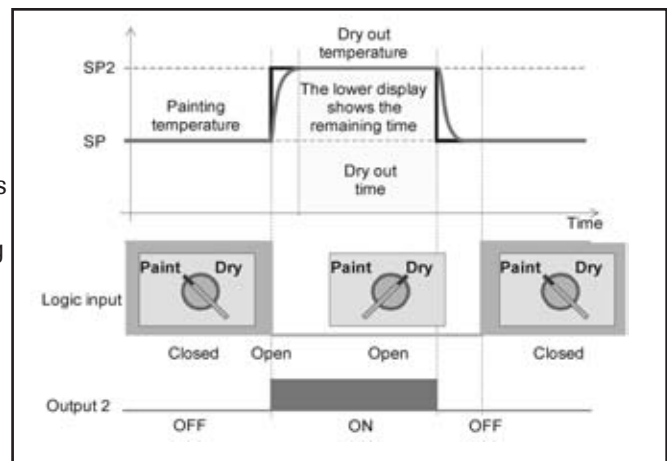

1603E Temperature Controller

CONFIGURATION PORT & KIT

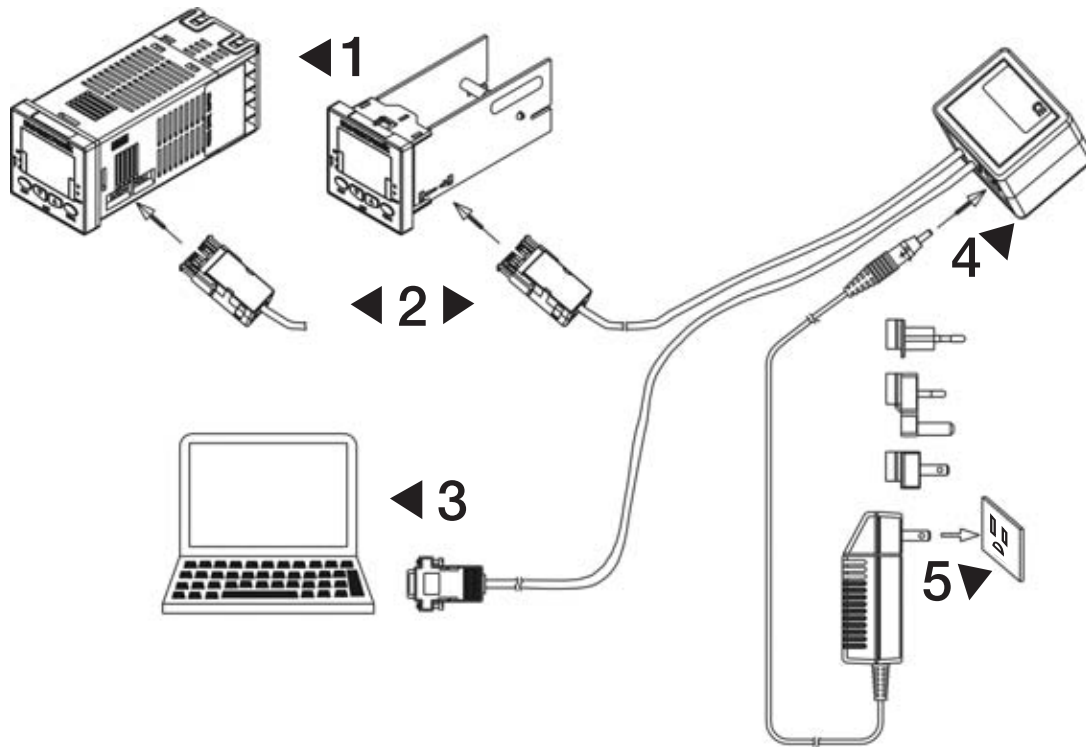

The 1603E can be connected to the remote Configuration Kit, CNFG-10000. This method of configuration is ideal for OEM's for quick setup and for resellers to easily program a controller for the specific needs of a customer.

Setup is simple:

1. Remove the 1603E from the shipping box or from the case.
2. Snap the push pin connector into the side of the 1603E.
3. Connect the 9 pin connector to the PC's RS232 port.
4. Connect the power Supply.
5. Download the Setup.

The controller doesn't need power. WIRING is Not required. The configuration software can download all the parameter. Special setups can be saved for future downloads.

The Configuration Kit CNFG-10000 consists of the following:

- Configuration Software Windows Based CDROM
- Hardware Connection Assembly
- Power Supply with Standard Wall Plug

The Hardware Connection Assembly has a 9 Pin RS232 connector for hook up to a PC COM Port, a specially designed connector for connection to the 1603E Configuration Port and a connection for the power supply.

1603E Temperature Controller

GENERAL SPECIFICATIONS

Front protection:	IP 65 and NEMA 4X for indoor locations (when panel gasket is installed)
Installation:	Panel mounting by means of mounting bracket. Instrument removable from case.
Rear terminal block:	10 screw terminals (screw M3, for cables from f 0.25 to f 2.5 mm ² or from AWG 22 to AWG 14) with connection diagrams and safety rear cover.
Dimensions:	1.9" (48mm) x 1.9" (48mm) x 4.13" (105mm) (DIN 43700)
Weight:	0.55 lbs. (250g) max
Power supply:	-100V to 240V AC 50/60Hz (-15% to + 10% of the nominal value) -24V AC/DC (+10% of the nominal value)
Power consumption:	6 VA max
Insulating voltage:	2300 V RMS according to EN 61010-1
Display updating time:	500 ms
Sampling time:	500 ms
Resolution:	30000 counts
Accuracy:	± 0.3% f.s.v. ± 1 digit @ 25°C ambient
Common mode rejection ratio:	120 dB at 50/60Hz
Normal mode rejection ratio:	60 dB at 50/60Hz
Electromagnetic compatibility: and safety requirements	CE directives 89/336/EEC, EN-50081-2 and EN-50082-2 directives 73/23/EEC and 93/68/EEC EN61010-1
Temperature drift:	< 400 ppm/°C for RTD or TC type T
Cold junction compensation error:	0.1°C/°C change in ambient
Temperature:	from 0 to 50°C
Storage temperature:	from -20 to +85°C
Humidity:	from 20% to 85% RH, non condensing
Timer:	10 seconds to 90 minutes

DIMENSIONS

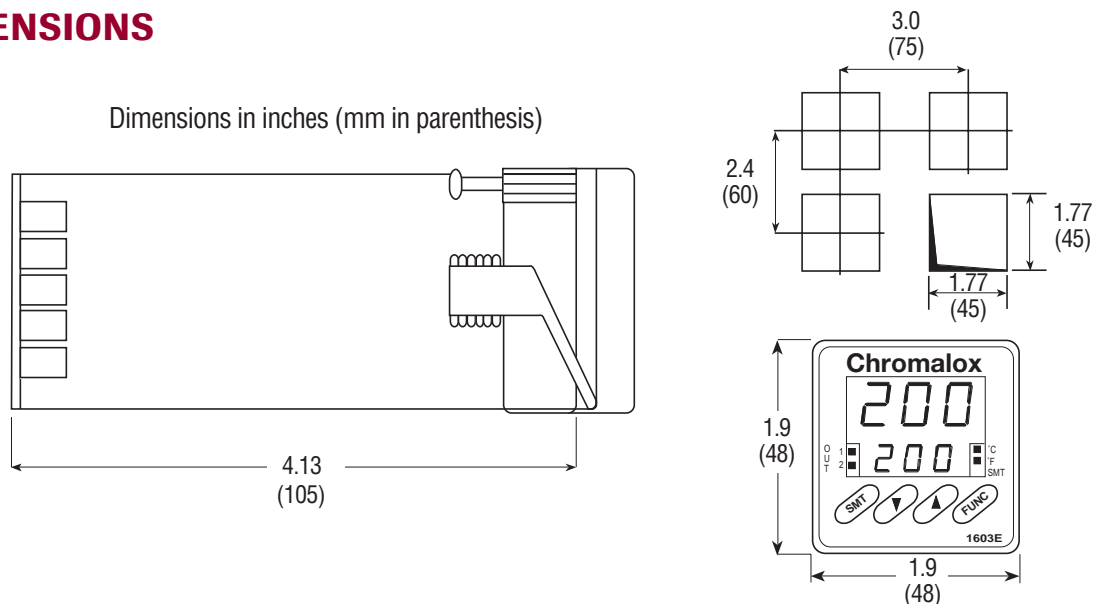

1603E Temperature Controller

INPUT SPECIFICATIONS

Thermocouples

Burn out: upscale on open input circuit detection (wires or sensor)
Cold junction: automatic compensation from 0 and 50 °C ambient
Cold junction compensation error: 0.1 °C/°C change in ambient

TC	°C	°F
	1603E	1603E
L	0 / 900	0 / 999
J	0 / 999	0 / 999
K	0 / 999	0 / 999
N	0 / 999	0 / 999
T	0 / 400	0 / 752

RTD

Type: 100 Ω RTD, 3 wire
Line resistance: automatic compensation up to 20 Ω/wire with:
- error $< \pm 0.1\%$ of the input span for range - 19.9 a 99.9 °C
- not measurable error for the other ranges
Engineering unit: programmable °C or °F
Burn out: detection of the sensor and of one or more wires open circuit. It shows the short circuit whenever the sensor resistance is lower than 15 Ω.

STANDARD RANGES TABLE:

RTD type	°C	°F
	1603E	1603E
PT 100	-199 / 800	-199 / 999
3 wire	-19.9 / 99.9	--

LOGIC INPUT

Type: external dry contact
Sampling Time: 300 ms
Contact rating: 8mA, 8 Vdc
Non Isolated

CONTROL ACTION

Algorithm: PID + SMART
Types: one control output (heating); two control outputs (heating and cooling)
Output types: relay or SSR
Output action: time proportional or on/off
Proportional band: from 1.0% (heating) or 1.5% (heating and cooling) to 100% of the input span
Hysteresis (dead band): (in On/Off control): from 0.1% to 10.0% of the input span
Integral time: from 1 second to 20 minutes
Derivative time: from 0 to 10 minutes
Integral preload:
- one control output, from 0 to 100% of the output range
- two control outputs, from -100% to 100% of the output range
Heating cycle time: from 1 to 200 seconds
Cooling cycle time: from 1 to 200 seconds
Relative cooling gain: from 0.20 to 1.00
Overlap/dead band: from - 20% to 50% of PB

OUTPUT 1 AND 2

Output 1 - Relay **Relay:** SPDT 3A @ 250VAC on resistive load
Output 1 - SSR Drive **Type:** nonisolated, 14VDC @ 20mA max. 24VDC @ 1mA
Output 2 & 3 - Relay **Relay:** SPST 2A @ 250VAC on resistive load

ALARM

Action: direct or reverse (normally de-energized or normally energized)
Alarm function: field selectable; Process - High or Low, input range, Band Alarm - Inside or Outside, 0-500 units, Deviation Alarm - High or Low, -199 to 500 units
Reset: Automatic or Manual, Non-Latching or Latching
Inhibit: Enable or Disable, Inhibits on Power Up and Set Point changes
Hysteresis: 0.1 to 10.0% of input span

1603E Temperature Controller

ORDERING INFORMATION

Model 1/16 DIN Temperature Controller

1603E 1/16 DIN Temperature Controller

Code Output 1 - Heat or Cool

- 1** Relay SPDT, 3A, 250Vac, resistive load
- 6** SSR drive, 14Vdc at 20mA

Code Output 2 - Cool or Alarm

- 0** None
- 1** Relay SPST, 2A, 250Vac, resistive load

Code Options

- 0** None
- 1** Alarm 2 relay, SPST, 2A, 250Vac, restrictive
- 2** Logic input for timer function or for switching SP1/SP2

Code Power Supply

- 3** 100 - 240Vac
- 5** 24 Vac or Vdc

Code

- 0** Add to complete part number

1603E - 1 1 0 3 0 Typical Model Number

In Stock

Part Number	PCN
1603E-11030	317577
1603E-61030	317585
1603E-11050	317593
1603E-61050	317606
1603E-11130	305947
1603E-61130	305955
1603E-11230	305963
1603E-61230	305971

Accessories

Part Number	PCN	Description
CNFG-10000	317614	Remote Configuration Kit
0149-01305	314448	Snubber

PDS 1603E
November 2003