

Chromalox[®]

PRECISION HEAT AND CONTROL

1601E 4 digit single display temperature controller
1603E Dual 3 digit display temperature controller

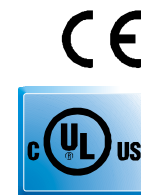
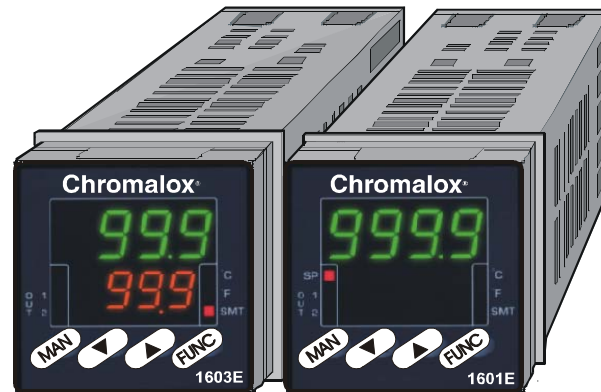

Issue date
November 2003

 **USER'S MANUAL**
0037-75420



A. 2



1601-03-A-CX.pmd

2

02/12/2003, 15.59



INDEX

A. ORDER TABLE	A. 1	8. MAINTENANCE	28
A. OUTLINE AND CUT OUT		B. DEFAULT PARAMETERS	B. 1
DIMENSIONS	A. 5		
1. MOUNTING	1		
2. ELECTRICAL CONNECTIONS.....	2		
3. GENERAL OPERATION	6		
4. CONFIGURATION	6		
4.1 Pushbutton function	6		
4.2 Possible protection of the parameters ...	6		
4.3 Access to the configuration			
procedure	7		
4.4 Configuration parameters	7		
5. OPERATOR MODE	14		
5.1 Preliminary comments	14		
5.2 Indicators	15		
5.3 Function of the pushbuttons	15		
5.4 Manual reset of the alarm	16		
5.5 SMART algorithm	16		
5.6 Inhibition of the out signal	16		
5.7 Direct modification of the set point	17		
5.8 Displaying the set point set			
(model LDE)	17		
5.9 Lamp test	17		
5.10 Operative parameters	18		
5.11 SP/SP2 Selection	20		
5.12 Timer mode description	20		
5.13 Soft Start Function	24		
6. ERROR MESSAGES	24		
6.1 Measurement anomaly signal	24		
6.2 Error messages	25		
6.3 List of possible errors	25		
7. TECHNICAL CHARACTERISTICS	26		
7.1 Technical specifications	26		
7.2 Inputs	26		
7.3 Control actions	27		
7.4 Outs	28		
7.5 CPI - Configuration Port Interface	28		

Model Identification

Model

1601E 4 digit single display

1603E Dual 3 digit display

Code Output 1 - Heat or Cool

1 Relay, 3 Amps at 250 Vac (Resistive)

6 SSR Drive, 14 Vdc at 20 mA

Code Output 2 - Alarm

0 None

1 Relay, 1 Amp at 250 Vac (Resistive load)

Code

0 Add to complete model number

1 Out 3 relay

2 Logic input

Code Instrument Power

3 100 - 240 Vac

5 24 Vac/dc

Code

0 Add to complete model number

1601E 1 1 0 3 0 Typical Model Number

A. OUTLINE AND CUT OUT DIMENSIONS

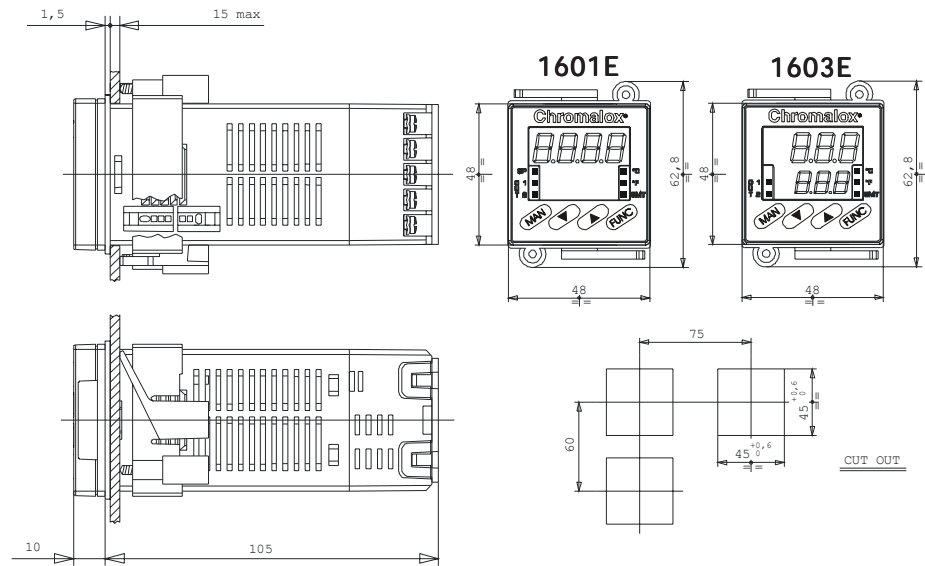

A. 5



A. 6



1601-03-A-CX.pmd

6

02/12/2003, 15.59



IMPORTANT SAVE THESE INSTRUCTIONS

1. MOUNTING

Select a mounting location where there is minimum vibration and the ambient temperature ranges between 0 and 50°C (32 and 122°F). The instrument can be mounted on a panel up to 15 mm thick with a square cutout of 45 x 45 mm. For outline and cutout dimensions refer to page A.4.

The surface texture of the panel must be better than 6.3 µm.

The instrument is fitted with a rubber panel gasket. To assure IP65 and NEMA 4 protection, insert the panel gasket between the instrument and the panel as shown in Fig. 1.

While holding the instrument against the panel proceed as follows:

- 1) insert the gasket in the instrument case;
- 2) insert the instrument in the panel cutout;
- 3) pushing the instrument against the panel, insert the mounting bracket;
- 4) with a screwdriver, turn the screws with a torque between 0.3 and 0.4 Nm.

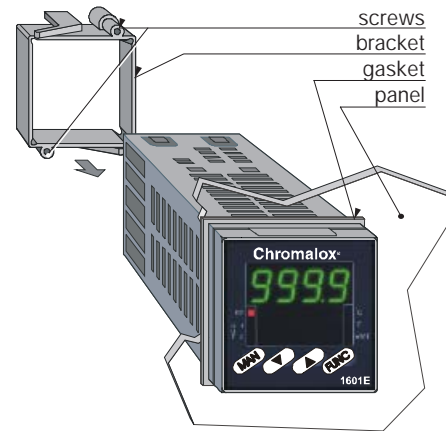

Fig. 1 PANEL MOUNTING

2. ELECTRICAL CONNECTIONS

WARNING

Electric shock Hazard

Disconnect all power before installing or servicing controller.

Failure to do so could result in personal injury or property damage.

Connections are to be made with the instrument housing installed in its proper location.

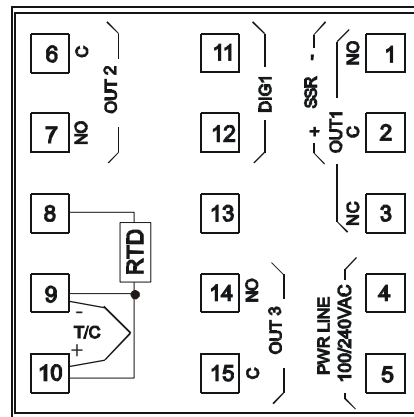

Fig. 2 REAR TERMINAL BLOCK

MEASURING INPUTS

SAFETY NOTE: Any external components (like zener barriers etc.) connected between sensor and input terminals may cause errors in measurement due to excessive and/or not balanced line resistance or possible leakage currents.

TC INPUT

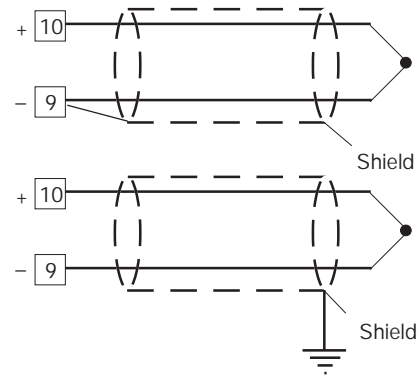

Fig. 3 THERMOCOUPLE CONNECTION

SAFETY NOTES:

- 1) Do not run input wires together with power line cables.
- 2) For TC wiring use proper compensating cable preferably shielded.
- 3) When a shielded cable is used, it should be connected at one point only.

RTD INPUT

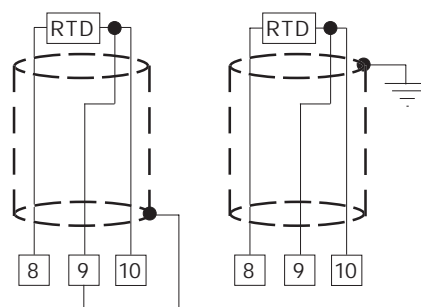

Fig. 4 RTD CONNECTION

SAFETY NOTES:

- 1) Do not run input wires together with power line cables.
- 2) Pay attention to the line resistance; a resistance higher than 20 Ω /wire may cause measurement errors.
- 3) When shielded cable is used, it should be grounded at one side only to avoid ground loop currents.
- 4) The impedance of the 3 wires must be the same.

LOGIC INPUT

SAFETY NOTE:

- 1) Do not run logic input wiring together with power cables.
- 2) Use an external dry contact capable of switching 8 mA, 8 V DC.
- 3) The instrument needs 300 ms to recognize a contact status variation.
- 4) The logic input is **NOT** isolated by the measuring input

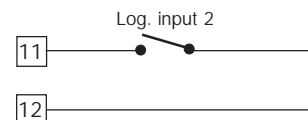

Fig. 5 - LOGIC INPUT WIRING

The logic input can be programmed as:

A) Set point selector

A.1) In this case it will operate as follows:

logic input	operat. set point
open	SP
close	SP2

B) Start timer

In this case it will operate as described at paragraph 5.10 (Timer modes description).

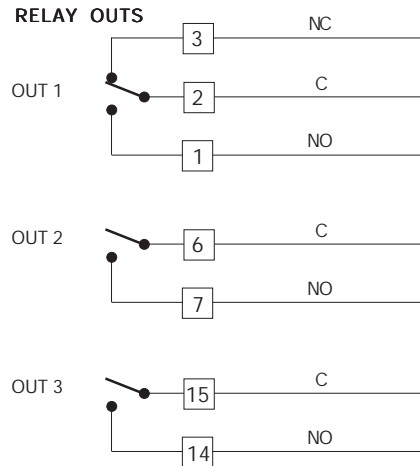

Fig. 5 RELAY OUTS
 The OUT 1 NO contact, the OUT 2 and OUT 3 contacts are protected by varistors against inductive load with inductive component up to 0.5 A.
 The OUT 1 contact rating is 3A/250V AC on resistive load.
 The OUT 2 and OUT 3 contact rating are 2A/250V AC on resistive load.
 The number of operations is 1×10^5 at specified rating.

⚠ WARNING

Electric shock Hazard

- 1) To avoid electric shock, connect the power line at the end of the wiring procedure.
- 2) For power connections use No 16 AWG or larger wires rated for at least 75°C.
- 3) Use copper conductors only.
- 4) Do not run input wires together with power



line cables.
 5) OUT 3 and logic input are mutually exclusive.

The follow these recommendations to avoid serious problems which may occur when using relay output to drive inductive loads.

INDUCTIVE LOADS

High voltage transients may occur when switching inductive loads.
 These transients may introduce disturbances through the internal contacts which can affect the performance of the instrument.
 The internal protection (varistors) assures correct protection up to 0.5 A of inductive component but the OUT 1 NC contact is not protected.
 The same problem may occur when a switch is used in series with the internal contacts.

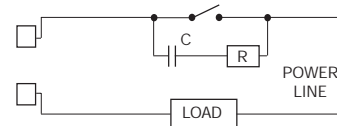

Fig. 6 EXTERNAL SWITCH IN SERIES WITH THE INTERNAL CONTACT

In these cases an additional RC network should be installed across the external contact as shown in Fig. 6

The value of the capacitor (C) and resistor (R) are shown in the following table.

LOAD (mA)	C (mF)	R (W)	P. (W)	OPERATING VOLTAGE
<40 mA	0.047	100	1/2	260 V AC
<150 mA	0.1	22	2	260 V AC
<0.5 A	0.33	47	2	260 V AC

In every case the cable connected to the relay outs must be routed as far away as possible from input or communication cables.

VOLTAGE OUTS FOR SSR DRIVE

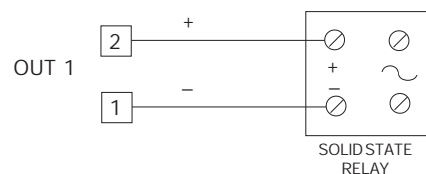

Fig. 7 SSR DRIVE OUT WIRING

It is a time proportioning out.

Logic level 0: Vout < 0.5 V DC.

Logic level 1: Maximum current = 20 mA.

- 14 V + 20 % @ 20 mA

- 24 V + 20 % @ 1 mA.

SAFETY NOTE: This out is NOT isolated.

A double or reinforced Isolation between instrument output and power supply must be assured by the external solid state relay.

POWER LINE WIRING

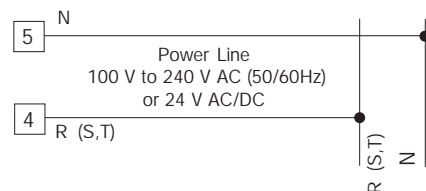

Fig. 8 POWER LINE WIRING

⚠ WARNING

Electric shock Hazard

- 1) Before connecting the instrument to the supply, make sure that the line voltage corresponds to that indicated on the rating plate.
- 2) To avoid electric shock, connect the power line at the end of the wiring procedure.
- 3) For supply connections use No 16 AWG or larger wires rated for at least 75°C.
- 4) Use copper conductors only.
- 5) Do not run input wires together with power line cables.
- 6) For 24 V AC/DC the polarity does not matter.
- 7) The power supply input has NO fuse protection. Please, provide a T type 1A, 250 V fuse externally.
- 8) The safety regulations for equipment permanently connected to the mains require that there is a switch or circuit breaker in the building electrical system and that this:
 - is near the device and can easily be reached by the operator;
 - is marked as the device ON/OFF .

NOTE: A single switch or circuit-breaker can drive more than one instrument.

3. GENERAL OPERATION

There are two setup modes for these models:

- Configuration mode
- Operator mode

In general, the configuration mode is the initial setup of the controller when first installed. Input type and alarm setup are examples of Configuration Mode settings. The Operator mode includes settings that might be adjusted frequently with daily control operations such as setpoints, and PID parameters.

4. CONFIGURATION

4.1 PUSHBUTTON FUNCTION

- FUNC** This saves the new value of the selected parameter and goes to the next parameter (increasing order).
- SMT** This scrolls back the parameters without saving the new value.
- ▲ This increases the value of the selected parameter.
- ▼ This decreases the value of the selected parameter.

4.2 POSSIBLE PROTECTION OF THE PARAMETERS

Access to the configuration, and the display and modification of the operative parameters, can be protected by a secret code. The code is entered in configuration, by means of parameters P11 and P14.

P11 = 0 All the operator parameters can be displayed and modified. Access to the configuration is free.

P11 = 1 and P14 = On All the operator parameters can be displayed but not modified, apart from SP (Set Point), SP2 and T. Access to the configuration is only possible by entering code 408 when requested.

P11 = 1 and P14 = OFF No operator parameter can be displayed and modified, apart from SP, SP2 and T. Access to the configuration is only possible by entering code 408 when requested.

P11 = 2/499 In this case the value programmed in P11 represents a numerical key which can be used to protect access to the configuration and, in operator mode, the modification of the parameters (SP can always be modified). To set P11 see section 4.4.

If the modification of the parameters has been enabled, the passage in configuration is free. If not it will be allowed by entering, when requested, the numerical value programmed in P11, or code 408.

P11 = 500/999 As for the previous point, with the difference that AL (alarm threshold) can be modified as well as SP, SP2 and T.

In the two previous cases, with P14 = On the parameters set as not modifiable can however be displayed. With P14 = OFF they are not.

4.3 ACCESS TO THE CONFIGURATION PROCEDURE

To access the configuration, press SMT and FUNC simultaneously (press first SMT and immediately afterwards FUNC) keeping both the pushbuttons pressed for three seconds.

In the model 1603E the lower display will show **CNF**, the upper **OFF**. In model 1601E **OFF** and **CNF** will appear alternatively.

Press ▲ or ▼ within 10 seconds to set **ON**, then confirm with FUNC.

If the device is in the protected condition (see previous section), the lower display (1603E) shows **CNF**, the upper a dashed line (instead of **OFF**). In model 1601E the two wordings appear alternately.

By means ▲ or ▼ enter the value entered in P11, or value 408. Press FUNC to confirm.

The instrument is now in configuration mode, and the display shows **CNF** steadily for both models. Via FUNC we advance to the first parameters.

In configuration, the lower display shows the code of the parameter (P1-P21), the upper the numerical value or the selection code. In the model 1601E, the display shows the parameter

code and the numerical value alternatively.

To alter the value set press ▲ or ▼ and confirm with FUNC.

The parameter for loading the default parameters is shown in section B at the end of the manual.

4.4 CONFIGURATION PARAMETERS

P1 - Type of input and standard range

	Type of input	Range	
0	TC type L	0 / +900 °C	
1	TC type J	0 / +999 °C	(1603E)
		0 / +1000 °C	(1601E)
2	TC type K	0 / +999 °C	(1603E)
		0 / +1370	(1601E)
3	TC type N	0 / +999 °C	(1603E)
		0 / +1400 °C	(1601E)
4	RTD type Pt 100	-199 / +800 °C	(1603E)
		-200 / +800 °C	(1601E)
5	RTD type Pt 100	-19.9 / +99.9 °C	(1603E)
		-199.9 / +400.0 °C	(1601E)
6	TC type T	0 / +400 °C	
8	TC type L	0 / 999 °F	(1603E)
		0 / 1652 °F	(1601E)
9	TC type J	0 / 999 °F	(1603E)
		0 / 1832 °F	(1601E)
10	TC type K	0 / 999 °F	(1603E)
		0 / 2498 °F	(1601E)
11	TC type N	0 / 999 °F	(1603E)
		0 / 2552 °F	(1601E)
12	RTD type Pt 100	-199 / 999 °F	(1603E)
		-328 / 1472 °F	(1601E)
13	TC type T	0 / 752 °F	

NOTE: On the instrument front panel two leds indicate the setting of the temperature in °C or °F, depending on the configuration.

P2 = Initial range value

Initial range value for input from thermocouple/
Resistance Temperature Detector.

NOTES:

- 1) When P2 has been modified, the **RL** parameter will be aligned to it and **RH** parameter will be forced to P3 value is **RH < RL**.
- 2) When P2 has been modified, if the alarms are programmed as process alarms (P5=1 and/or P22=1) and the alarm thresholds are out of range, **RL.1** and/or **RL.2** will be aligned to P2.

P3 = Full range value

Full range value for input from thermocouple/
Resistance Temperature Detector.

NOTES: The minimum input span (P3 - P2) is 300°C or 600°F for TC input and 100°C or 200°F for RTD input.

On every parameter change P1, P2 is forced to the minimum value, P3 to the maximum value.

If the value of P2 and/or P3 is modified the parameter rL is automatically aligned to the new value (of P2 and/or P3).

If P5 = 1, parameter rL is checked and automatically aligned if it is out of range.

P4 = Out 1 action

This parameter is not modifiable when P5 = 5

REU = reverse action (Heating)

DIR = direct action (Cooling)

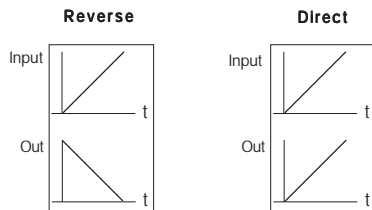

P5 = Function of Out 2

0 = Not used or used as event (P22 = 3, 4, 6, 7)

1 = Alarm 1 output - Process alarm

2 = Alarm 1 output - Band alarm

3 = Alarm 1 output - Deviation alarm

4 = Alarm 1 output - Instrument failure alarm

5 = Cooling out

NOTES:

1) Setting P5 = 1, 2, 3:

- if parameter **DLH** is less than 0, it is set to 100;

- if parameter **IP** is less than 0, it is set to 30;

- if parameters **RL.1** is out of range, it will be aligned to the lowest value.

2) Setting P5 = 0 or 4:

- if parameter **DLH** is less than 0, it is set to 100;

- if parameter **IP** is less than 0, it is set to 30;

3) Setting P5 = 5:

- parameter P4 automatically assumes the value "**REU**";

- if parameter P16 is out of range, it will be aligned to the lowest value;

- if parameter Pb is not 0 and is lower than 1.5, it is set to 1.5.

4) Setting P5 different 0:

- if P22 parameter is equal to 3, 4, 6 or 7 it will be forced to 0.

P6 = Configuration Out 2

P6 is skipped when P5 = 0.

If P5 = 1, 3 or 4;

H.R. = High alarm with automatic reset

L.R. = Low alarm with automatic reset

H.L. = High alarm with manual reset

L.L. = Low alarm with manual reset

When P5 = 4, the "high" or "low" selection has no effect.

If P5 = 2:

H.R. = *out of band* with automatic reset

LR = *in band* with automatic reset

HL = *out of band* with manual reset

LL = *in band* with manual reset

When P5 = 5 this parameter selects the cooling medium.

RIR = air **OIL** = oil **H2O** = water

NOTE: Modifying parameter P6 automatically updates the values of the cooling cycle time and the cooling gain.

P6	C2	RC
Air	10 (s)	1
OIL	4 (s)	0.8
H2O	2 (s)	0.4

P7 = Alarm action

Only available when P5 is different from 0 or 5.

REU = reverse (relay de-energized in alarm condition)

JIR = direct (relay energized in alarm condition)

P8 = Alarm inhibit

Only available when P5 is 1, 2 or 3.

OFF = inhibit disabled

DN = inhibit enabled

NOTE: The alarm inhibit function disables the alarm indication at instrument start up and after a set point modification until the process variable reaches the alarm threshold.

P9 = OFFSET applied to the measured value

This OFFSET is applied along the whole span.

When P1 = 5 P9 is programmable from -19.9 to 19.9°C.

When P1 ≠ 5 P9 is programmable from -199 to 199°C or °F.

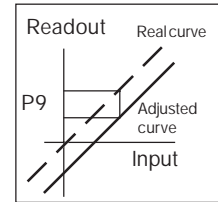

P10 = Threshold of the "Soft Start" function

The "Soft start" function limits the maximum out power (see **OLH** operator parameter) for a programmable time (see **TOL** operator parameter) at the instrument start up when the measured value is lower then the programmed threshold. P10 is the threshold value, in engineering units. If **TOL** = **INF**, P10 value is not considered.

Every time parameter P1 is changed it is forced to the minimum value.

P11 = Safety lock

0 = device unlocked. All the parameters can be modified

1 = device locked. None of the parameters can be modified except the **SP**, **SP2** and **T**.

2 to 499 = **SP**, **SP2** and **T** can be always modified.

Select the secret code (to be remembered) and during the "operative mode" and scrolling the "software key" parameter, the display will show one of the following figures:

A)



The device is "Unlocked" and all parameters can be modified.

B)



To make the device "Locked" enter a number different from the "secret code".

The key is enabled: no parameter can be modified apart from **SP**, **SP2** and **T**.
To "Unlock" the device, insert the "secret code".

500 to 999: Selecting a secret code between these two numbers, everything will occur as explained above except that when the device is "Locked" the parameters that can be modified are the set point and the alarm threshold and the time.

NOTE: The instrument shows on the display the value **2** for any value of P11 between 2 and 999.

P12 = Out maximum rate of rise

This parameter is only available if **P5** is not 0.
Programmable from 1 to 25% of the out signal per second.
Over 25%/s the instrument displays "**INF**" to indicate the exclusion of the limitation.

P13 = Not used

P14 = Protected parameters display

This parameter is only available if P11 is not 0.
This parameter enables/disables the display of the protected parameter during "operator mode".
OFF = the protected parameters are not displayed
ON = the protected parameters are displayed

P15 - SMART function enabling/disabling

0 = The SMART function is disabled
1 = SMART function enabling/disabling is **NOT** protected by the safety code.
2 = SMART function enabling/disabling is protected by the safety code.

P16 - Maximum value of the proportional band automatically settable by the SMART function

This parameter is available if P15 is not 0. It can assume the following values:
model 1603E: between P17 or P18 and 99.9%
model 1601E: between P17 or P18 and 100.0%

P17 - Proportional minimum band value automatically settable by the SMART function (one control out only)

This parameter is only displayed if P5 is not 5 or P15 is not 0.
It may be programmed from 1.0% to the value of P16.

P18 - Proportional minimum band value automatically settable by the SMART function (two control outs, heating/cooling)

This parameter is only present if P5 is 5 and P15 is not 0.
This parameter may be programmed from 1.5% to the value of P16.

P19 = Automatic calculation of "relative cooling gain"

This parameter is only present if P5 is 5 and P15 is not 0.

OFF = the SMART function does **NOT** calculate the "relative cooling gain".

ON = the SMART function calculates the "relative cooling gain".

P20 = Minimum integral time value calculated by the SMART function

This parameter is only present if P15 is not 0.

It can assume the following values:

model 1603E: between 0.1 (1 tenth of a second) and 2.0 (2 minutes)

model 1601E: between 00.01 (1 second) and 2.00 (2 minutes).

P21 = Extension of the anti-reset-wind up

Span: from -30 to +30 % of the proportional band.

NOTE: a positive value increases the high limit of the anti-reset-wind up (over set point) while a negative value decreases the low limit of the anti-reset-wind up (under set point).

The advanced configuration procedure is completed and the instrument shows "**CONF**" on the display.

To quit the configuration, press SMT and FUNC simultaneously (press first SMT and immediately afterwards FUNC) keeping both the pushbuttons pressed for three seconds.

P22 - Option selection (out 3 or digital input)

- 0 = output not used
- 1 = Alarm 2 output - Process alarm
- 2 = Alarm 2 output - Band alarm
- 3 = Alarm 2 output - Deviation alarm
- 4 = Digital input used for SP/SP2 selection.
- 5 = Timer mode 1 (see below)
- 6 = Timer mode 2 (see below)
- 7 = Timer mode 3 (see below)
- 8 = Timer mode 4 (see below)
- 9 = Timer mode 5 (see below)
- 10 = Timer mode 6 (see below)
- 11 = Timer mode 7 (see below)

Note:

- 1) Select P22 value in accordance with the installed hardware.
- 2) Setting P22 equal to 1, 2 or 3, if **RL2** parameter is out of range, it will be aligned to its low limit.
- 3) Setting P22 equal to 4, 5 or 8, if **SP2** parameter is out of range, it will be aligned to **RL** value.
- 4) Setting P22 equal to 6 or 7, P5 parameter will be forced to 0 and if **SP2** parameter is out of range, it will be aligned to **RL** value.
- 5) Setting P22 equal to 9 or 10, P5 parameter will be forced to 0.
- 6) When P22 parameter pass from a value equal or greater than 9 to a value lower than 9, at the next start up the control output will be forced to "enabled".

Timer functions

Notes about all timer modes:

- 1) At power off the time value and status will be reset.
- 2) The time parameter (**T**) can always be modified but the new value become operative at the next start time only.

Timer mode 1 [P22 = 5]

If the logic input remains in open condition for more than a programmed time the instrument goes automatically at a stand by temperature (SP2). The time count is reset when the logic input is closed.

For other details see paragraph **"5.7 Timer modes description"**.

Timer mode 2 [P22 = 6]

When the contact is closed, the instrument controls using SP as operative set point. When the contact has been opened the instrument selects SP2 as operative set point and starts the time count down.

Note that the guarantee soak function can be applied to this timer mode (see P28 parameter) When the time count is equal to 0 the instrument comes back to the SP set point and the output 2 will be energized. The Out 2 reset will be made when the logic input will be closed again.

For other details see paragraph **"5.7 Timer modes description"**.

Timer mode 3 [P22 = 7]

When the contact is closed, the instrument controls using SP as operative set point. When the contact has been opened the instrument operate as follows:

- it selects SP2 as operative set point
- it starts the time count down
- it energizes the Output 2

Note that the guarantee soak function can be applied to this timer mode (see P28 parameter)

When the time count is equal to 0 the instrument comes back to the SP set point and the output 2 will be reset.

For other details see paragraph **"5.7 Timer modes description"**.

Timer mode 4 [P22 = 8]

The instrument operates using SP set point and the timer is normally reset. When the instrument detects the transfer from contact open to close it selects SP2 as operative set point and starts the time count down.

Note that the guarantee soak function can be applied to this timer mode (see P28 parameter) When the time count is equal to 0 the instrument comes back to the SP set point.

For other details see paragraph **"5.7 Timer modes description"**.

Timer mode 5 [P22 = 9]

The instrument start in "Power OFF" mode and it remains in "Power OFF" mode until the contact is closed. When the contact has been opened the instrument starts the control using SP set point and starts the time count down.

Notes:

- 1) The guarantee soak function can be applied to this timer mode (see P28 parameter)
- 2) The transfer from "Power OFF" mode to AUTOMATIC mode starts the "Soft start" and the "alarm masking" functions (if programmed).

When the time count is equal to 0 the instrument comes back to the "Power OFF" mode and the output 2 will be energized.

The Out 2 reset will be made when the logic input will be closed.

For other details see paragraph "**5.7 Timer modes description**".

Timer mode 6 [P22 = 10]

The instrument starts in "Power OFF" mode and it remains in "Power OFF" mode until the contact is closed.

When the contact has been opened the instrument operate as follows:

- it starts the control using SP set point.
- it starts the time count down
- it energizes the Output 2

Notes:

- 1) The guarantee soak function can be applied to this timer mode (see P28 parameter)
- 2) The transfer from "Power OFF" mode to AUTOMATIC mode starts the "Soft start" and the "alarm masking" functions (if programmed).

When the time count is equal to 0 the instrument comes back to the "Power OFF" mode and the output 2 will be reset.

For other details see paragraph "**5.7 Timer modes description**".

Timer mode 7 [P22 = 11]

The instrument starts in "Power OFF" mode and it remains in "Power OFF" mode until a transfer from open to close of the logic input is detected.

When the instrument detects the transfer from contact open to close it starts the control using SP set point and starts the time count down.

Notes:

- 1) The guarantee soak function can be applied to this timer mode (see P28 parameter)
- 2) The transfer from "Power OFF" mode to AUTOMATIC mode starts the "Soft start" and the "alarm masking" functions (if programmed).

When the time count is equal to 0 the instrument comes back to the "Power OFF" mode .

For other details see paragraph "**5.7 Timer modes description**".

P23 = Alarm 2 configuration

P23 is skipped when P22 is equal to 0

If P22 = 1 or 3

H.R. = *High alarm* with automatic reset

L.R. = *Low alarm* with automatic reset

H.L. = *High alarm* with manual reset

L.L. = *Low alarm* with manual reset

If P22 = 2:

H.R. = *out of band* with automatic reset

L.R. = *in band* with automatic reset

H.L. = *out of band* with manual reset

L.L. = *in band* with manual reset

P24 = Alarm 2 action

P24 is available when P22 is 1, 2 or 3.

REU = reverse (relay de-energized in alarm condition)

JIR = direct (relay energized in alarm condition)

P25 = Stand-by of the alarm 2

P25 is available when P5 is 1, 2 or 3.

OFF = stand-by disabled

ON = stand-by enabled

NOTE: The alarm stand-by function disables the alarm indication at instrument start up and after a set point modification until the process variable reaches the alarm threshold.

P26 = treshould of the guarantee soak function

P26 is available when P22 is greater than 2.
This function stop automatically the time count down when the measured value is out of the band defined by the set point plus and minus P26 value.

- When P1 = 5 : P26 is programmable from 0.1 to 50.0 eng. units.
- When P1 ≠ 5 : P26 is programmable from 1 to 500 eng. units.

Above max value the display shows "OFF" and this finction is disabled.

The configuration procedure is completed and the instrument shows "CNF" on the display.

To quit the configuration, press SMT and FUNC simultaneously (press first SMT and immediately afterwards FUNC) keeping both the pushbuttons pressed for three seconds.

5. OPERATOR MODE

The display and modification of the operator parameters can be protected by a secret code. For more information see section 4.2.

5.1 PRELIMINARY COMMENTS

It is assumed, at this point, that the instrument has been correctly configured as indicated in Section 4.

- Model 1603E displays the value measured on the upper display: the lower display is normally used to display the operating set point (below this condition is defined as "Normal display").
- Model 1601E displays the value measured (below this condition is defined as "Normal display") or, alternatively, the operating set point (in this case the SP led lights up).
To change from the display of the set point to that of the value measured, or vice versa, press pushbutton ▲.

All the parameters can be displayed sequentially by pressing the FUNC pushbutton.

- Model 1603E displays the abbreviated name of the parameter selected on the lower display, on the upper display the value set.
- Model 1601E displays alternatively the name of the parameter and its value: during the modification it displays only the value.

To modify the setting of a parameter proceed as follows:

- 1) By means of the FUNC pushbutton select the parameter to be modified.
- 2) Using the ▲ and ▼ keys set the value required.

- 3) Press the FUNC pushbutton to save the new value and go to the next parameter.
- 4) Press SMT to return to the previous parameter without saving.

NOTES:

- 1) If, during parameter modification, no pushbutton is pressed for more than 10 seconds, the instrument automatically reverts to the "normal display mode" and the new setting of the last parameter will be lost.
- 2) In the "normal display", on pressing pushbutton ▲ or ▼ and keeping it pressed for more than two seconds, one can directly access the set point value, which can be modified by pressing ▲ or ▼ again (see section 5.7).
- 3) The instrument does not display all the possible parameters, but only those which are in agreement with:
 - a) The instrument configuration (see section 4).
 - b) The setting of parameter P14 (see section 4).
 - c) The setting of the proportional band (see section 5.5).

5.2 INDICATORS

- SMT Flashes when the first part of the SMART algorithm is active.
Lit when the second part of the SMART algorithm is active.
- OUT1 Lit up when out 1 is ON.
- OUT2 A) When used as event or cooling output it lit up when out 2 is ON.
B) When used as alarm indication:
B.1) Lit if only Alarm1 is in alarm condition.
B.2) Flashing at slow rate (0.5 Hz) if only Alarm 2 is in alarm condition.
B.3) Flashing at fast rate (2 Hz) if both

- alarms are in alarm condition.
- °C Lit up if the temperature is displayed in °C.
- °F Lit up if the temperature is displayed in °F.
- SP (1601E only) Lit when the display shows the operative set point.

In addition:

- a) The decimal point on the right hand of the LSD of the upper display, for 1603E, or of the display, for 1601E, flashes when the instrument is working with SP2.
- b) The decimal point on the left hand of the LSD of the lower display, for 1603E, or of the display, for 1601E, flashes when the display shows the time count down.

5.3 FUNCTION OF THE PUSHBUTTONS

- FUNC Saves the new value of the selected parameter and goes to the next parameter (increasing order).
- SMT Enables or disables the SMART function and scrolls back all the parameters without saving them.
- ▲ Increases the value of the selected parameter or (1601E only) displays the set point value or the measured value.
- ▼ Decreases the value of the selected parameter.
- ▼ + FUNC Enables/disables the "LAMP TEST".

NOTE: The operator parameters must be modified within 10 seconds. If, during operator parameter modification, no pushbutton is pressed during this time, the instrument automatically reverts to the "normal display mode". Saving only the parameter modifications which were followed by pressing the FUNC pushbutton.

5.4 MANUAL RESET OF THE ALARM

If the alarm has been configured as a latched alarm, the alarm status persists even after the alarm condition disappears.

To reset the alarm, press the FUNC pushbutton to select the parameter "HRS" (the display will show "HRS" and "OFF"). Use the ▲ and ▼ pushbuttons to select "ON" and press the FUNC pushbutton. The alarm reset action will only be successful if the alarm condition has disappeared.

5.5 SMART ALGORITHM

This function gives best process control. To enable the SMART function, press the SMT pushbutton for more than 1.5 s, when the instrument is in normal display mode. The SMT LED will be lit continuously or flash according to the algorithm automatically selected.

When the SMART function is enabled, the traditional control parameters (P, I, D and RC) can be displayed but not modified.

When the traditional control (PID) is desired, press the SMT pushbutton again (for more than 1.5 s) to turn the "SMART" OFF. The instrument maintains the actual control parameters setting and allows parameter modification.

NOTES:

- 1) During operation of the SMART function, the relative cooling gain (if controlled by SMART) is limited within the following ranges:

Cooling medium	Span
Air	0.85 to 1.00
OIL	0.80 to 0.90
H ₂ O	0.30 to 0.60

- 2) The SMART function uses a derivative time equal to 1/4 of the integral time.

- 3) The limits of the proportional band settable by the SMART function are programmed by parameters P16, P17 and P18.
- 4) The lower limit of the integral time settable by the SMART function is programmed by parameter P20.
- 5) When ON/OFF control is programmed (Pb=0), the SMART function is disabled.
- 6) SMART enabling/disabling can be protected by the safety lock (see parameter P15).

5.6 INHIBITION OF THE OUT SIGNAL

This feature manually turn OFF the control output. To turn the out signal OFF, press the ▲ pushbutton first and then press the FUNC pushbutton.

Keeping them both pressed for more than 3 seconds.

The instrument will display "OFF" instead of indicating the set point; the out signal will switch OFF and the instrument will work as a simple indicator.

When the control outs are disabled, the alarms are also disabled and forced to the no-alarm condition. The modification of the control parameters is still enabled.

To return to normal control, press the ▲ pushbutton first and then press the FUNC pushbutton. Keeping them both pressed for more than 3 seconds, the instrument returns to normal display mode.

NOTES :

- 1) If the out is turned OFF when the SMART function is performing the first part of the SMT algorithm (LED SMT flashing), the SMART function will be aborted and when the instrument comes back to the normal control, the SMART function will be disabled.



If the out is turned OFF when the SMART function was performing the second part of the SMT algorithm (LED SMT lit), the SMART function will be stopped and, when the instrument comes back to the normal control, the smart function will also be activated.

- 2) If the instrument is turned OFF with the out power off function enabled, at the next start up this function will automatically be enabled again.

5.7 DIRECT MODIFICATION OF THE SET POINT

The set point value can be modified without using the FUNC pushbutton.

When direct access to set point modification is required, proceed as follows:

- 1) Press pushbutton ▲ or ▼ for more than 2 seconds; the set point value will be displayed and it will start to change.
- 2) Using the ▲ and ▼ pushbuttons, set the desired value.
- 3) When the desired value is reached, DO NOT press any pushbutton, the new set point will become operative 2 seconds after the pushbuttons were last pressed and the instrument will return to the "normal display".

If during this procedure the modification is not to be saved, press the FUNC pushbutton immediately (within 2 seconds); the instrument automatically returns to the normal display without saving the new set point.

5.8 DISPLAYING THE SET POINT SET (model 1601E)

To display the set point set, press the ▼ pushbutton. The SP led lights up. The set point value will appear on the display.

To return to the display of the value measured press pushbutton ▼ again.

5.9 LAMP TEST

To check the display efficiency, press pushbuttons ▼ + FUNC. The instrument will turn ON, with a 50% duty cycle, all the LEDs of the display (this state is called LAMP TEST).

No time out is applied to the LAMP TEST.

To return to the normal display mode, press pushbuttons ▼ + FUNC again.

No other keyboard functions are available during the LAMP TEST.



5.10 OPERATIVE PARAMETERS

The following is a list of all the available control parameters.

Note that some parameters may not be displayed depending on the specific instrument configuration.

To modify the setting of a parameter proceed as follows:

- 1) By means of the FUNC pushbutton select the parameter to be modified.
- 2) Using the ▲ and ▼ keys set the value required.
- 3) Press the FUNC pushbutton to save the new value and go to the next parameter.
- 4) Press SMT to return to the previous parameter without saving.

NOTES:

- 1) If, during parameter modification, no pushbutton is pressed for more than 10 seconds, the instrument automatically reverts to the "normal display mode" and the new setting of the last parameter will be lost.
- 2) The instrument does not display all the possible parameters, but only those which are in agreement with:
 - a) The instrument configuration (see section 4).
 - b) The setting of parameter P14 (see section 4).
 - c) The setting of the proportional band (see section 5.5).

Param. Description

SP Set point (in eng. units).
Span: from rL to rH.

N.RS Manual reset of the alarms.
This parameter is displayed if one alarm has been programmed with manual reset.

Set ON and press the FUNC pushbutton to reset the alarms.

SP2 Set point 2 (in eng. units).
This parameter is present if P22 = 1, 2, 3, 4 or 5.

Span: from rL to rH.

T time of the timer function (in minutes and seconds).

This parameter is present if P22 greater than 4.

Span: from 10 seconds (00.1) to 90 minutes (90.0).

NNN Software key for parameter protection.

This parameter is skipped if P11 = 0 or 1.

ON = the instrument is in LOCK condition
OFF = the instrument is in UNLOCK condition.

To switch from LOCK to UNLOCK, set a value equal to the value of parameter P11.

To switch from UNLOCK to LOCK, set a value different from the value of parameter P11.

Span: 2/999

RL. I Alarm 1 threshold (in eng. units).
This parameter is available only if

P5 = 1, 2 or 3.

Spans:

- From P2 to P3 for process alarm (P5 = 1)

- From 0 to 500 units for band alarm (P5 = 2).

- From -199 to 500 units for deviation alarm (P5 = 3).

H5. I Alarm 1 hysteresis (in % of P3 - P2 span).

This parameter is available only if

P5 = 1, 2 or 3.

Span: From 0.1% to 10.0% of the input

- span or 1 LSD.
- Note:** If the hysteresis of a band alarm is larger than the alarm band, the instrument will use an hysteresis value equal to the alarm band minus 1 digit.
- AL.2** Alarm 2 threshold (in eng. units). This parameter is available only if P22 = 1, 2 or 3.
Spans:
- From P2 to P3 for process alarm (P5 = 1)
- From 0 to 500 units for band alarm (P5 = 2).
- From -199 to 500 units for deviation alarm (P5 = 3).
- HS.2** Alarm 1 hysteresis (in % of P3 - P2 span). This parameter is available only if P22 = 1, 2 or 3.
Span: From 0.1% to 10.0% of the input span or 1 LSD.
Note: If the hysteresis of a band alarm is larger than the alarm band, the instrument will use an hysteresis value equal to the alarm band minus 1 digit.
- P 1** Proportional band (in % of P3 - P2 span).
Span:
- For one control output: from 1.0% to 99.9% (from 1.0% to 100.0% for model 1601E) of the input span (P3-P2).
- For two control outputs: from 1.5% to 99.9% (from 1.5% to 100.0% for model 1601E) of the input span (P3-P2)
When the the SMART is ON (see section 5.2) the value of Pb is limited to that set in P16-P17 (one control action) and to that set on P16-P18 (two control actions).
When Pb parameter is set to 0, the instrument performs an ON-OFF control;
- the ti, td, IP, C, C2, rC, OLP, OLH and tOL parameters are skipped and the "output max. rate of rise" and SMART functions are not available.
- HS** Hysteresis for ON/OFF control action (in % of P3 - P2 span). This parameter is only available when Pb = 0.
Span: from 0.1% to 10.0% of the input span.
- T I** Integral time. Is skipped when Pb = 0 (ON/OFF action).
Span model 1603E: from 0.1 to 20.0 mm.s (minutes and tens of seconds).
Span model 1601E: from 00.01 to 20.00 mm.ss (minutes and seconds)
Above this value the display becomes dark and the integral action is excluded.
- T D** Derivative time. This parameter is skipped if Pb = 0 (ON/OFF action).
Span model 1603E: from 0.00 to 9.59 mm.ss (minutes and seconds)
Span model 1601E: from 0.00 to 10.00 mm.ss (minutes and seconds).
If 0 is set, the derivative action is excluded.
- IP** Integral pre-load. This parameter is only available when Pb is not 0.
Span:
- from 0 to 100% for one control output
- from -100 to 100% for two control outputs.
- C** Out 1 cycle time (in seconds). This parameter is only available when Pb is not 0.
Span: from 1 to 200 s.
- C 2** Out 2 cycle time (in seconds). C2 is only available if Pb is not 0 and P5 is 5.

- RC** Span: from 1 to 200 s.
Relative Cooling gain.
This is skipped if Pb = 0 (ON/OFF action) or P5 is not 5.
- OLP** Span: from 0.20 to 1.00
Dead band/Overlap between H/C outs (in % of the proportional band).
"OLP" is skipped if Pb = 0 (ON/OFF action) or P5 is not 5.
A negative value shows a dead band while a positive value shows an overlap.
Span: from -20 to 50%.
- RL** Set point low limit (in eng. units).
Span: from min. range value (P2) to rH.
Note: when rL value has been changed, if the SP and SP2 value are lower than the new rL value, they will be aligned to the new rL value.
- RH** Set point high limit (in eng. units).
Range: from rL to full scale value (P3).
Note: when rH value has been changed, if the SP and SP2 value are higher than the new rH value, they will be aligned to the new rH value.
- OLH** Out maximum limit (in % of the out).
Span:
- From 0 to 100 when the instrument is configured with one control out.
- From -100 to 100 when the instrument is configured for two control outs.
- TOL** Duration of the out power limiter (in minutes).
Available only if Pb is not 0.
Span: from 1 to 540 min. Above this limit, the display shows "INF" and the limitation is always entered.
Note: Parameter tOL can be modified but the new value will only become operative at the next instrument start up unless the new value is **INF**.

5.11 SP/SP2 SELECTION

When P22= 0 the set point 2 is not available.
When P22 = 1, it is possible to select the operating set point (SP or SP2) by the logic input only (terminals 11 and 12).
When P22 > 1 the set point selection is managed by timer function and no manual selection is available

5.12 Timer modes description

Timer mode 1 [P22 = 5]

If the logic input remains in open condition for more than a programmed time the instrument goes automatically to a stand by temperature (SP2).
The time count is reset when the logic input is closed.

1603E display management: the upper display shows the measured value while the lower display shows the operative set point.

1601E display management: the display shows the measured value.

Pushing ▲ pushbutton it is possible to display the operative set point.

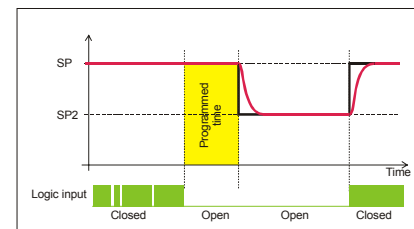

Timer mode 2 [P22 = 6]

When the contact is closed, the instrument controls using SP as operative set point. When the contact has been opened, the instrument selects SP2 as operative set point and starts the time count down. When the time count is equal to 0 the instrument comes back to the SP set point and the output 2 will be energized. The Out 2 reset will be made when the logic input will be closed again.

1603E display management: when the instrument starts the time count down, the upper display shows the measured value while the lower display shows time count down.

1601E display management: when the instrument starts the time count down, the display shows the time count down.

Pushing ▲ pushbutton it is possible to display the measured value.

NOTE: for both instruments, when the time is finished the instrument comes back to the normal display mode.

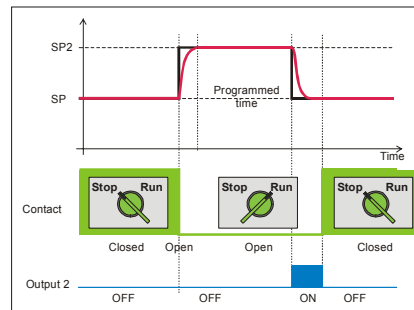

Timer mode 3 [P22 = 7]

When the contact is closed, the instrument controls using SP as operative set point. When the contact has been opened the instrument operates as follows:

- it selects SP2 as operative set point
- it starts the time count down
- it energizes the Output 2

When the time count is equal to 0 the instrument comes back to the SP set point and the output 2 will be reset.

1603E display management: when the instrument starts the time count down, the upper display shows the measured value while the lower display shows time count down.

1601E display management: when the instrument starts the time count down, the display shows the time count down.

Pushing ▲ pushbutton it is possible to display the measured value.

NOTE: for both instruments, when the time is finished the instrument comes back to the normal display mode.

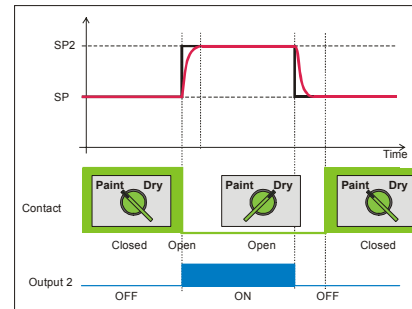

Timer mode 4 [P22= 8]

The instrument operates using SP set point and the timer is normally reset.

When the instrument detects the transfer from contact open to close it selects SP2 as operative set point and starts the time count down.

When the time count is equal to 0 the instrument comes back to the SP set point.

1603E display management: when the instrument starts the time count down, the upper display shows the measured value while the lower display shows time count down.

1601E display management: when the instrument starts the time count down, the display shows the time count down.

Pushing ▲ pushbutton it is possible to display the measured value.

NOTE: for both instruments, when the time is finished the instrument comes back to the normal display mode.

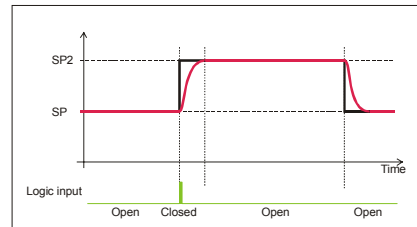

Timer mode 5 [P22 = 9]

The instrument starts in "Power OFF" mode and it remains in "Power OFF" mode until the contact is closed.

When the contact has been opened the instrument starts the control using SP set point and starts the time count down.

When the time count is equal to 0 the instrument comes back to the "Power OFF" mode and the output 2 will be energized.

The Out 2 reset will be made when the logic input will be closed.

1603E display management: when the instrument starts the time count down, the upper display shows the measured value while the lower display shows time count down.

1601E display management: when the instrument starts the time count down, the display shows the time count down.

Pushing ▲ pushbutton, it is possible to display the measured value.

NOTE: for both instruments, when the time is finished the instrument comes back to the usual display of the Power OFF mode.

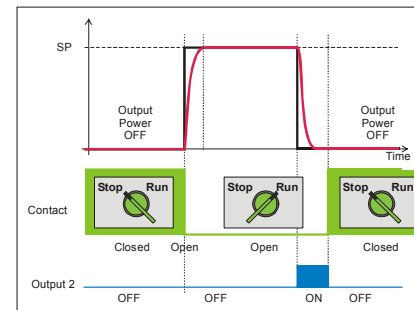

Timer mode 6 [P22 = 10]

The instrument starts in "Power OFF" mode and it remains in "Power OFF" mode until the contact is closed.

When the contact has been opened the instrument operates as follows:

- it starts the control using SP set point.
- it starts the time count down
- it energizes the Output 2

When the time count is equal to 0 the instrument comes back to the "Power OFF" mode and the output 2 will be reset.

1603E display management: when the instrument starts the time count down, the upper display shows the measured value while the lower display shows time count down.

1601E display management: when the instrument starts the time count down, the display shows the time count down.

Pushing ▲ pushbutton, it is possible to display the measured value.

NOTE: for both instruments, when the time is finished the instrument comes back to the usual display of the Power OFF mode.

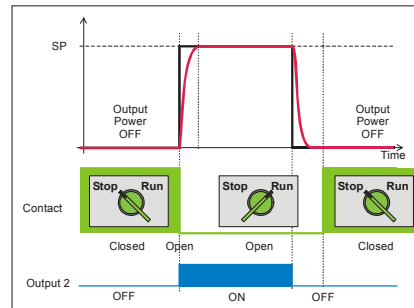

Timer mode 7 [P22 = 11]

The instrument starts in "Power OFF" mode and it remains in "Power OFF" mode until a transfer from open to close of the logic input is detected.

When the instrument detects this transfer, it starts the control using SP set point and starts the time count down.

When the time count is equal to 0 the instrument comes back to the "Power OFF" mode .

1603E display management: when the instrument starts the time count down, the upper display shows the measured value while the lower display shows time count down.

1601E display management: when the instrument starts the time count down, the display shows the time count down.

Pushing ▲ pushbutton, it is possible to display the measured value.

NOTE: for both instruments, when the time is finished the instrument comes back to the usual display of the Power OFF mode.

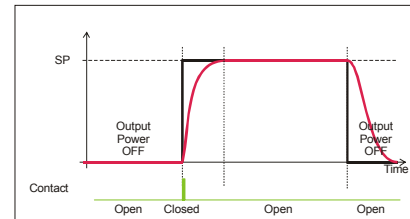

5.13 "Soft Start" FUNCTION

At power up, the instrument will measure the process variable and compare the measured value with a programmed threshold (see P10 parameter in chapter 4).

If the measured value is lower than the programmed value, the instrument will limit the maximum output power (see OLH operative parameter) for a programmed time (see tOL operative parameter).

If tOL is equal to InF, the limiter is ever active.

6. ERROR MESSAGES

6.1 MEASUREMENT ANOMALY SIGNAL

The instrument display (the upper display for model 1603E) shows the OVERRANGE and UNDERRANGE conditions with the following indications:

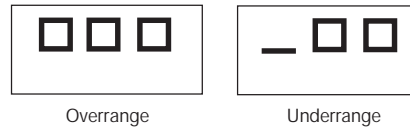

*The example shows the display of model 1603E.
Model 1601E displays 4 digits.*

- The sensor break can be signalled as:
- for TC/mV input : OVERRANGE or
UNDERRANGE selected by
a solder jumper
 - for RTD input : OVERRANGE

On RTD input, a special test is provided to signal OVERRANGE when input resistance is less than 15 ohm (Short circuit sensor detection).

NOTE:

When:

- The instrument is set for one control out only and an OVERRANGE is detected, the OUT 1 turns OFF (if reverse action) or ON (if direct action).
- The instrument is set to use two control outs and an OVERRANGE is detected, OUT 1 turns OFF and OUT 2 turns ON.
- The instrument is set for one control out only and an UNDERRANGE is detected, the OUT 1 turns ON (if reverse action) or OFF (if direct action).

- The instrument is set to use two control outs and an UNDERRANGE is detected, OUT 1 turns ON and OUT 2 turns OFF.

For inputs from thermocouple the underrange indication can be selected as shown in section 7.2 of this manual.

NOTE: When an *overrange* or an *underrange* is detected, the alarms operate as if the instrument had detected the maximum or the minimum measurable value respectively.

To eliminate the out of span condition, proceed as follows:

- 1) Check the input signal source and the connecting line.
- 2) Make sure that the input signal is in accordance with the instrument configuration. Otherwise, modify the input configuration (see section 4).
- 3) If no error is detected, send the instrument to your supplier to be checked.

6.2 ERROR MESSAGES

Diagnostics are made on switching on and during normal operation.

If the instrument detects an error condition the display will show:

1603E: "ERR" in the lower display and the code which identifies the type of error in the upper display.

1601E: "E" and the error code.

The complete list of all the possible errors follows in numerical order.

Some errors automatically reset the instrument: if the error persists, send the instrument to your supplier to be checked.

6.3 LIST OF POSSIBLE ERRORS

- 100** EEPROM writing error.
Consult your supplier.
- 150** Generic CPU error.
Consult your supplier.
- 2# #** Error in the configuration parameters.
The two less significant figures indicate the number of the incorrect parameter (e.g. **209 ERR** indicates error of parameter P9).
Press SMT and FUNC, then set the parameter correctly.
See section 4.
- 30 I** RTD input calibration error.
Contact your supplier.
- 305** TC input calibration error.
Contact your supplier.
- 307** RJ input calibration error.
Contact your supplier.
- 400** **Error in the operator parameters. To deal with the problem, enter the predefined parameters ("Default Parameters", see section B), pressing pushbuttons ▼ and ▲ at the same time. Then set the operator parameters. This will not reset the configuration parameters.**
- 500** Auto-zero error
Contact your supplier.
- 502** RJ error
Contact your supplier.
- 5 10** Error during calibration.
Contact your supplier.

7. TECHNICAL CHARACTERISTICS

7.1 TECHNICAL SPECIFICATIONS

Case: ABS grey (RAL 7043); self-extinguishing degree: V-0 according to UL 94.

Front protection - designed and tested for IP 65(*) and NEMA 4X for indoor locations (when panel gasket is installed).

(*) *Tests were performed in accordance with CEI 70-1 and NEMA 250-1991.*

Installation: panel mounting

Rear terminal block: 10 screw terminals (screw M3, for cables from ϕ 0.25 to ϕ 2.5 mm² or from AWG 22 to AWG 14) with connection diagrams and safety terminal block cover.

Dimensions: according to DIN43700 48 x 48 mm, depth 105 mm.

Weight: 200 g max.

Power supply:

- 100V to 240V AC 50/60Hz (-15% to + 10% of the nominal value).

- 24 V AC/DC (+ 10 % of the nominal value).

Power consumption: 9 VA max / 4 W.

Insulation voltage: 2300 V rms according to EN 61010-1.

Display updating time: 500 ms.

Sampling time: 500 ms.

Resolution: 30000 counts.

Precision: + 0.3% v.f.s. + 1 digit @ 25°C of room temperature.

Common mode rejection: 120 dB at 50/60 Hz.

Normal mode rejection: 60 dB at 50/60 Hz.

Electromagnetic compatibility and safety requirements: This instrument is marked CE.

It therefore conforms to directives 89/336/EEC (reference harmonized standard CEI EN-61326-1:1998 and CEI EN-61326/A1:1999 emission re-

quirements: residential environment - class B – for 100/240V AC and industrial environment - class A – for 24V AC/DC) and to directives 73/23/EEC and 93/68/EEC (reference harmonized standard EN 61010-1).

Installation category: II

Temperature drift: < 200 ppm/°C (RJ excluded) < 400 ppm/°C for RTD input and input from thermocouple T.

< 800 ppm/°C for RTD input with 1/10°C resolution (model 1603E).

< 500 ppm/°C for RTD input with 1/10°C resolution (model 1601E).

Operating temperature: from 0 to 50°C (from 32 to 122°F).

Storage temperature: -30 to +70°C (-22 to 158°F)

Humidity: from 20 % to 85% RH, non condensing.

Protections:

1) WATCH DOG (hardware/software) for the automatic restart.

7.2 INPUTS

A) THERMOCOUPLES

Type: L, J, K, N, T programmable from the keypad.

Line resistance: max. 100 Ω with error <+0.1% of the input span.

Engineering units: °C or °F programmable.

Reference junction: automatic compensation from 0 to +50°C (from 32 to 122°F).

Reference junction drift : 0.1°C/°C.

Burn-out: Up or down range selectable.

Calibration: according to IEC 584-1 and DIN 43710 - 1977 (TC L).
TABLE OF STANDARD RANGES

Type of TC	Measuring spans	
	<i>In brackets the data of model 1601E</i>	
L	0 / +999 (1652)°F	0 / +900°C
J	0 / +999 (1832)°F	0 / +999 (1000)°C
K	0 / +999 (2498)°F	0 / +999 (1370)°C
N	0 / +999 (2552)°F	0 / +999 (1400)°C
T	0 / +752 °F	0 / +400 °C

B) RTD (Resistance Temperature Detector)
Type: Pt 100 3 wire connection.
Current: 135 µA.
Line resistance: automatic compensation up to 20 Ω/wire with :
 - error <+1% of the input span when P1 = 5.
 - not measurable error for the other spans.
Engineering units: °C or °F programmable.
Burn-out: up range.
NOTE: A special test is provided to signal OVERRANGE when input resistance is less than 15 Ω.
Calibration: according to DIN 43760.

TABLE OF STANDARD RANGES

RTD type	Measuring span <i>In brackets the data of model 1601E</i>	
RTD Pt 100	-199 / +800 °C (-200 / +800 °C)	-199 / +999 °F (-328 / +1472 °F)
RTD Pt 100	-19.9 / +99.9 °C (-199.9 / +400.0 °C)	- -

C) Logic Input

Type: external dry contact .
Sampling time: 300 ms.
Contact rating: 8 mA, 8 V DC.

NOTES:

- 1) The "OUT 3" and the "logic input" options are mutually exclusive.
- 2) The logic input is **NOT** isolated by the measuring input

7.3 CONTROL ACTIONS

Control actions: PID or SMART
Proportional band: from 1.0 % (if just one control out is used) or 1.5 % (if two control outs are used) to 99.9% (1603E) 100% (1601E) of the input span.
 On setting Pb = 0 an ON/OFF control is performed.
Hysteresis (for ON/OFF control): from 0.1% to 10.0% of the input span.
Integral time: from 0.1" to 20' (1603E); from 1" to 20' (1601E). If a value of more than 20 minutes is set the integral action is excluded.
Derivative time: from 0 to 9'59" (1603E); from 0 to 10'00" (1601E).
Integral preload:
 - from 0 to 100% for one control out.
 - from -100 to 100% for two control outs.
Main out (out 1) cycle time: from 1 to 200 s.
Cooling out (out 2) cycle time: from 1 to 200 s.
Cooling action gain: from 0.20 to 1.00
NOTE: Parameters PB, TI, TD and RCG may be limited when the SMART function is enabled.
Overlap/dead band: from - 20 % to 50%.

7.4 OUTS

OUT 1 (Heating):

Relay out with SPDT contact;

- a) Out contact 3A / 250 V AC on resistive load.
- b) Logic voltage for solid state relay command.
Logic state 1: 24 Vdc +20% @ 1mA,
14V +20% @20 mA
Logic state 0: <0.5V

OUT 2 (Cooling or alarm 1)

Relay out with SPST contact;

Out contact 2A/250V AC on resistive load.

OUT 3 (alarm 2)

Relay out with SPST contact;

Out contact 2A/250V AC on resistive load.

NOTE: the "OUT 3" and the "logic input" options are mutually exclusive.

7.5 CPI – CONFIGURATION PORT INTERFACE

The instrument has a lateral socket into which a special five-pin connector can be inserted. This connector, supplied as an option together with its interface, can connect to the RS232 port of a normal PC on which the management software must be installed.

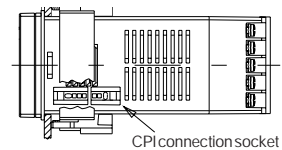

By means of the software the configuration can be managed directly from the PC. In this case the instrument display and keypad are not operative.

8. MAINTENANCE

⚠ WARNING

Electric shock Hazard

Disconnect all power before servicing controller. Failure to do so could result in personal injury or property damage.

- 1) SWITCH THE EQUIPMENT OFF (power supply, relay out, etc.).
- 2) Take the instrument out of its case.
- 3) Using a vacuum cleaner or a compressed air jet (max. 3 kg/cm²) remove all deposits of dust and dirt which may be present on the louvers and on the internal circuits being careful not to damage the electronic components.
- 4) To clean external plastic or rubber parts use only a cloth moistened with:
 - Ethyl Alcohol (pure or denatured) [C₂H₅OH] or
 - Isopropyl Alcohol (pure or denatured) [(CH₃)₂CHOH] or
 - Water (H₂O).
- 5) Make sure that there are no loose terminals.
- 6) Before putting the instrument back in its case, make sure that it is perfectly dry.
- 7) Put the instrument back and turn it ON.

B. DEFAULT PARAMETERS

DEFAULT OPERATIVE PARAMETERS

The control parameters can be loaded with predetermined default values. These data are the typical values loaded in the instrument prior to shipment from factory. To load the default values proceed as follows:

- The SMART function should be disabled.
- The safety lock must be OFF.
- The upper display will show the process variable while the lower display will show the set point value or the current measure (1603E type).
- In normal display mode, held down ▼ pushbutton and press ▲ pushbutton; the display will show:



The image shows a rectangular display area with the text "DL.F" in a bold, monospaced font.

- Within 10 seconds press ▲ pushbutton. The display will show:



The image shows a rectangular display area with the text "DL.N" in a bold, monospaced font.

- Press FUNC pushbutton; the display will show:



The image shows a rectangular display area with the text "L.DT." in a bold, monospaced font.

This means that the loading procedure has been initiated. After about 3 seconds the loading

procedure is terminated and the instrument reverts to NORMAL DISPLAY mode.

The following is a list of the default operative parameters loaded during the above procedure:

PARAM.	DEFAULT VALUE
<i>SP</i>	= minimum range-value
<i>SP2</i>	= minimum range-value
<i>T</i>	= 8.0 mm.s
<i>N.R5</i>	= OFF
<i>AL.1</i>	= minimum range-value for process alarms; 0 for deviation or band alarms
<i>HS.1</i>	= 0.1 %
<i>AL.2</i>	= minimum range-value for process alarms; 0 for deviation or band alarms
<i>HS.2</i>	= 0.1 %
<i>P1</i>	= 4.0 %
<i>HS</i>	= 0.5 %
<i>T1</i>	= 1603E: 04.0 1601E: 04.00 (4 minutes)
<i>T2</i>	= 1603E: 1.00 1601E: 01.00 (1 minute)
<i>IP</i>	= 30 % for one control output 0 % for two control outputs
<i>C</i>	= 20 seconds
<i>C2</i>	= 10 seconds for P6 = Alr 4 seconds for P6 = OIL 2 seconds for P6 = H2O
<i>RC</i>	= 1.00 for P6 = Alr 0.80 for P6 = OIL 0.40 for P6 = H2O
<i>OLP</i>	= 0
<i>RL</i>	= initial scale value (P2)
<i>RH</i>	= full scale value (P3)
<i>OLH</i>	= 100 %
<i>TOL</i>	= infinite

DEFAULT CONFIGURATION PARAMETERS

The configuration parameters can be loaded with predetermined default values. These data are the typical values loaded in the instrument prior to shipment from factory. To load the default values proceed as follows:

a) In "normal display mode", press SMT and FUNC pushbutton for more than 3 secs.

1603E

OFF
CNF

1601E (alternatively)

CNF
OFF

b) Push the ▲ or ▼ pushbutton; display will show:

ON
CNF

ON

c) Press FUNC to confirm.

CNF

CNF

d) Press the ▼ pushbutton; display will show the firmware version.

CNF
A.02

A.02

e) Maintaining the pressure on the ▼ pushbutton, push the ▲ pushbutton too. The instrument will show:

DL.F

f) Press ▲ pushbutton to select between table 1 (european) or table 2 (american) default parameter set. The display will show:

DL.1

g) Press FUNC pushbutton; the display will show:

L.DT

This means that the loading procedure starts. After about 3 seconds the loading procedure is terminated.

CNF

CNF

h) Press SMT and FUNC pushbutton for more than 3 secs.

The following is a list of the default parameters loaded during the above procedure:

PRODUCT	1601E		1603E	
PARAMETER	TABLE 1	TABLE 2	TABLE 1	TABLE 2
P1	1	9	1	9
P2	0 °C	0 °F	0 °C	0 °F
P3	400 °C	1000 °F	400 °C	999 °F
P4	r	r	r	r
P5	0	0	5	5
P6	H.A	H.A	Air	Air
P7	rEV	rEV	rEV	rEV
P8	OFF	OFF	OFF	OFF
P9	0	0	0	0
P10	0	0	0	0
P11	0	0	0	0
P12	25	25	25	25
P13	--	--	--	--
P14	ON	ON	ON	ON
P15	2	2	2	2
P16	30.0	30.0	30.0	30.0
P17	1.0	1.0	1.0	1.0
P18	--	--	1.5	1.5
P19	--	--	OFF	OFF
P20	00.30	00.30	00.3	00.3
P21	10	10	10	10
P22	0	0	0	0
P23	H.A.	H.A.	H.A.	H.A.
P24	rEV	rEV	rEV	rEV
P25	OFF	OFF	OFF	OFF
P26	OFF	OFF	OFF	OFF

Warranty And Limitation Of Remedy And Reliability

Chromalox warrants only that the Products and parts manufactured by Chromalox, when shipped, and the work performed by Chromalox when performed, will meet all applicable specification and other specific product and work requirements (including those of performance), if any, and will be free from defects in material and workmanship under normal conditions of use. All claims for defective or nonconforming (both hereinafter called defective) Products, parts or work under this warranty must be made in writing immediately upon discovery, and in any event, with three (3) years from delivery, provided, however all claims for defective Products and parts must be made in writing no later than three (3) years after shipment by Chromalox. Defective and nonconforming items must be held for Chromalox's inspections and returned to the original f.o.b. point upon request.

THE FOREGOING IS EXPRESSLY IN LIEU OF ALL OTHER WARRANTIES WHATSOEVER, EXPRESS, IMPLIED AND STATUTORY, INCLUDING, WITHOUT LIMITATION, THE IMPLIED WARRANTIES OF MERCHANTABILITY AND FITNESS FOR A PARTICULAR PURPOSE. Notwithstanding the provisions of this WARRANTY AND LIMITATION Clause, it is specifically understood that Products and parts not manufactured and work not performed by Chromalox are warranted only to the extent and in the manner that the same are warranted to Chromalox by Chromalox's vendors, and then only to the extent that Chromalox is reasonably able to enforce such warranty, it being understood Chromalox shall have no obligation to initiate litigation unless Buyer undertakes to pay all cost and expenses therefore, including but not limited to attorney's fees, and indemnifies Chromalox against any liability to Chromalox's vendors arising out of such litigation. Upon Buyer's submission of a claim as provided above and its substantiation. Chromalox shall at its option either (i) repair or replace its Products, parts or work at the original f.o.b. point of delivery, or (ii) refund an equitable portion of the purchase price.

THE FOREGOING IS CHROMALOX'S ONLY OBLIGATION AND BUYER'S EXCLUSIVE REMEDY FOR BREACH OF WARRANTY, AND IS BUYER'S EXCLUSIVE REMEDY AGAINST CHROMALOX FOR ALL CLAIMS ARISING HEREUNDER OR RELATING HERETO WHETHER SUCH CLAIMS ARE BASED ON BREACH OF CONTRACT, TORT (INCLUDING NEGLIGENCE AND STRICT LIABILITY) OR OTHER THEORIES. BUYER'S FAILURE TO SUBMIT A CLAIM AS PROVIDED ABOVE SHALL SPECIFICALLY WAIVE ALL CLAIMS FOR DAMAGES OR OTHER RELIEF, INCLUDING BUT NOT LIMITED TO CLAIMS BASED ON LATENT DEFECTS. IN NO EVENT SHALL BUYER BE ENTITLED TO INCIDENTAL OR CONSEQUENTIAL DAMAGES AND BUYER SHALL HOLD CHROMALOX HARMLESS THEREFROM. ANY ACTION BY BUYER ARISING HEREUNDER OR RELATING HERETO, WHETHER BASED ON BREACH OF CONTRACT, TORT (INCLUDING NEGLIGENCE AND STRICT LIABILITY) OR OTHER THEORIES, MUST BE COMMENCED WITHIN THREE (3) YEARS AFTER THE DATE OF SHIPMENT OR IT SHALL BE BARRED. **W2008M**

Return the defective part or product, freight prepaid, to:
Chromalox
1382 Heil-Quaker Blvd.
LaVergne, TN# 37086-3536

||
—

||
—

—
||

—
||



170.IU0.16X.E01

Chromalox®

1382 HEIL QUAKER BOULEVARD
LAVERGNE, TN 37086-3536

PHONE (615) 793-3900

FAX (615) 793-3563

TOLL-FREE NUMBER 888-996-9258

WEB SITE ADDRESS www.mychromalox.com

